

Networking Evolved, Strengthened Resilience

EDS-4000/G4000 Series Industrial Managed Switches

- Industry-leading network security with IEC 62443-4-2 compliance
- Superior 90 W PoE and 2.5GbE connectivity
- Multiple industrial certifications
- Advanced usability with intuitive web GUI and rotatable power module



Your Trusted Partner in Automation

Moxa is a leading provider of edge connectivity, industrial computing, and network infrastructure solutions for enabling connectivity for the Industrial Internet of Things (IIoT). With 35 years of industry experience, Moxa has connected more than 82 million devices worldwide and has a distribution and service network that reaches customers in more than 80 countries. Moxa delivers lasting business value by empowering industries with reliable networks and sincere service. Information about Moxa's solutions is available at www.moxa.com.

Moxa Americas

USA

Toll Free: 1-888-MOXA-USA
Tel: +1-714-528-6777
Fax: +1-714-528-6778
usa@moxa.com

Brazil

Tel: +55-11-95261-6545
brazil@moxa.com

Moxa Europe

Tel: +49-89-413-25-73-0
europe@moxa.com

Moxa Asia-Pacific and Taiwan

Asia/Taiwan

Tel: +886-2-8919-1230
Fax: +886-2-8522-8623
asia@moxa.com
taiwan@moxa.com

India

Tel: +91-80-4172-9088
Fax: +91-80-4132-1045
india@moxa.com

Russia

Tel: +7-495-287-0929
Fax: +7-495-269-0929
russia@moxa.com

Korea

Tel: +82-2-6268-4048
Fax: +82-2-6268-4044
korea@moxa.com

Japan

Tel: +81-3-6721-5670
Fax: +81-3-6721-5671
japan@moxa.com

Moxa China

Shanghai

Tel: +86-21-5258-9955
Fax: +86-21-5258-5505
china@moxa.com

Beijing

Tel: +86-10-5976-6123/24/25/26
Fax: +86-10-5976-6122
china@moxa.com

Shenzhen

Tel: +86-755-8368-4084/94
Fax: +86-755-8368-4148
china@moxa.com



Network Management Platform



Secure Networking & Cybersecurity



Next-generation Managed Switches



Unmanaged Switches



Industrial Wireless

Redefining a Connected Tomorrow

It's time to make sure your networks are prepared for a changing world. When it comes to operational resilience, those industries that have started to transform through IT/OT convergence have achieved better operational continuity and flexibility than those that have not.

As an industrial networking pioneer, Moxa's expertise continues to help customers succeed. We are dedicated to innovating ways to optimize your industrial network communications. Our solutions help you adapt quickly to trends and changes by further integrating IT and OT, pushing previously closed OT communications into the open cloud, and bringing more IT into the control field.

Our next-generation network solutions facilitate seamless IT/OT integration and provide enhanced network security, scalable performance, solid reliability, and simplified management to increase your operational resilience and efficiency.

Defense-in-depth Network Security

Build robust network security at every level, from real-time visibility, network segmentation, and security-hardened infrastructure to preemptive threat detection, analysis, and intelligent response to threats.

Futureproof Network Infrastructure

Transform your network's performance to meet demands for speed, versatility, and reliability with smart designs and innovative flexibility.

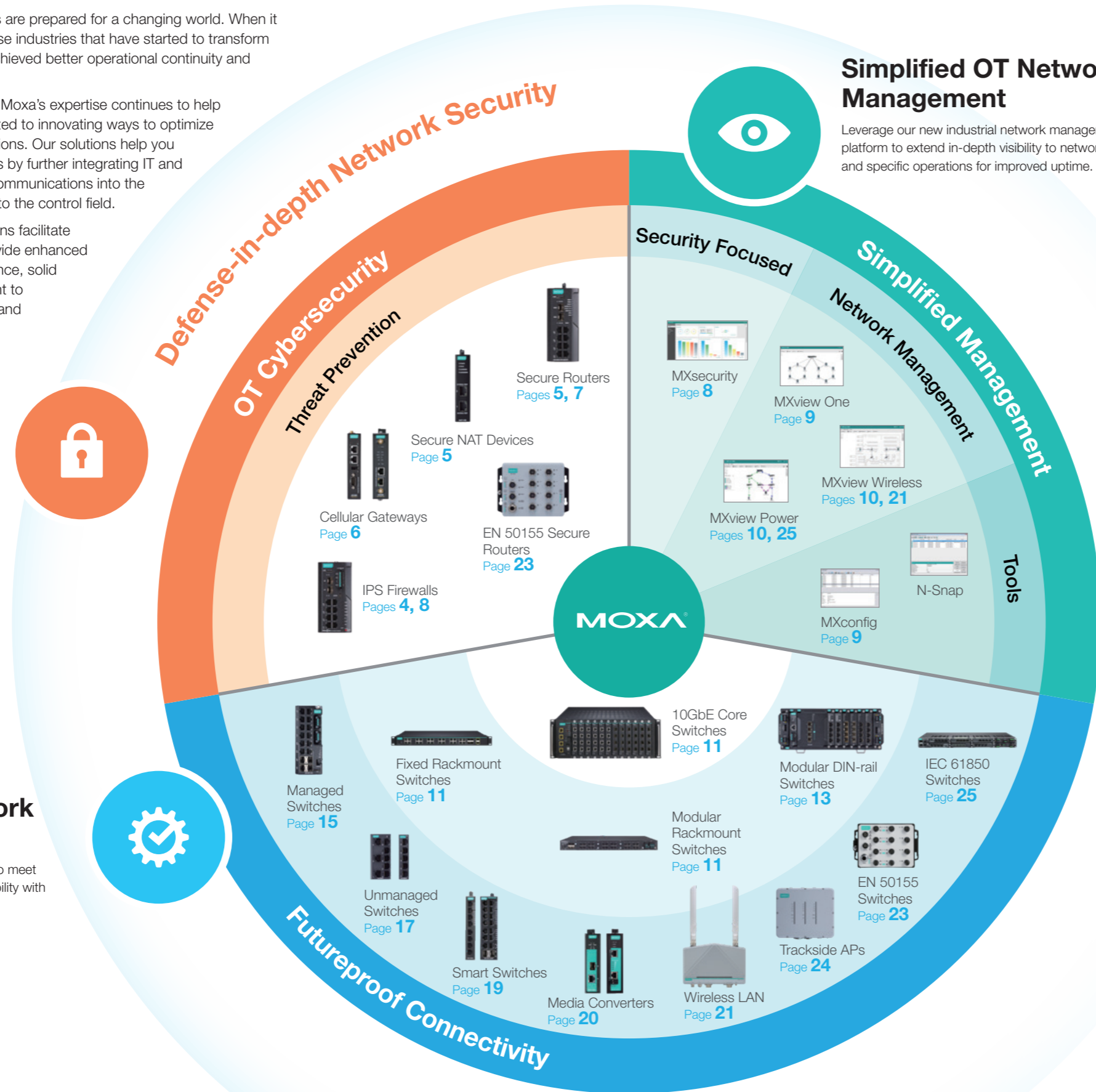

HIGHLIGHTS

Smart Flexibility for Future Success



See page 15

Stronger OT Network Defense



See pages 5-8

Visualize OT Security



See pages 7-8

Extend OT Application-specific Visibility



See pages 9-10

MXview One is a scalable network management platform that provides operation-specific visualization to help simplify IT/OT converged management through wired and wireless connection visibility and substation network monitoring. The MXview Wireless and MXview Power add-on modules combine best practices and in-depth OT visibility to enhance network optimization and availability.

Strengthen the Defense of Your Industrial Networks

Cyberthreats are escalating at a time when industries and companies must shift to remote and distributed operations. With a low tolerance for downtime, industrial control system (ICS) networks are frequently subjected to cyberattacks. It is critical for every industry to strengthen their security infrastructure and cyberdefense against cyberattacks to ensure maximum operational uptime and safety.

Following the guidelines defined by the IEC 62443 standards, Moxa provides holistic OT/IT integrated network security solutions that enhance OT-tailored network security with three layers of defense-in-depth protection.



Identify Network Statuses

Moxa provides centralized visibility of OT networks and security statuses to help customers detect and respond to cyberthreats quicker.



MXview One Industrial Network Management

- Full visibility of real-time network statuses, traffic, and activity
- Security View for viewing the security level of network devices
- Scalable add-on modules for vertical market applications, including MXview Wireless and MXview Power



MXsecurity Network Security Management

- Centralized network security and unified policy management
- Full visibility of real-time network security activities and threat analysis
- Unified mass deployment of security configurations and virtual patch updates
- Aggregates security logs based on configurable security policies to issue real-time alerts



Moxa Remote Connect Suite Secure Remote Access Management

- Cloud-based remote access solution with an embedded firewall and allowlist for access control
- AES-256 encryption to protect data
- Smart IP mapping for easy IP management in the field



Security Dashboard Console Security Management

- Centralized cybersecurity management with real-time dashboards
- OT visibility that includes device identification and a network traffic analyzer
- Automatically deploy virtual patches without disrupting operations

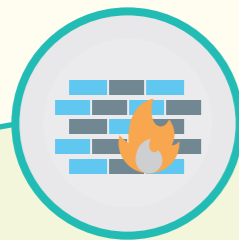

Protect Your Networks

Moxa uses a defense-in-depth strategy to protect network infrastructure through secure segmentation and threat defense.

First, create secure segments by using VLANs, VPNs, firewalls, access control, DPI, and applying security policies to security controls. Then, enhance threat defenses by using IDS/IPS devices and virtual patching.



EDR-G9010 Series Industrial Secure Routers

- All-in-one firewall/NAT/VPN/router/switch for network segmentation, data encryption, and security control
- Access control and traffic filtering with OT protocol deep packet inspection
- IPS/IDS functions for defense against malicious activity



IEC-G102-BP Series Industrial IPS/IDS Devices

- Ultra-compact industrial security box with IPS/IDS
- Fine-grained policy enforcement with allowlist control
- Bump-in-the-wire installation without impacting the network



IEF-G9010 Series Industrial IPS Firewall

- Compact, security-hardened, and rugged design
- Fine-grained Layer 2 to Layer 7 firewall policy with IPS capability
- Industrial NAT and a network segmentation



Select Secure Devices

Following IEC 62443 standards, Moxa's industrial Ethernet products prioritize security features during the design and development phases to define a new benchmark for industrial network reliability, including:

- Industrial Ethernet Switches
- Industrial Serial Device Servers
- Industrial Protocol Gateways
- Modular Remote I/Os



Moxa Security Advisories

Moxa's Product Security Incident Response Team (PSIRT) takes a proactive approach to protect our products from security vulnerabilities and help our customers better manage security risks. Stay informed by scanning this QR code to subscribe to our Security Advisories and receive notifications about product vulnerabilities and security updates.



EDS-4000/G4000 Series 8/9/12/14 Port Managed Switches

- Secure by design in compliance with IEC 62443-4-1 and IEC 62443-4-2 standards
- Developed according to IEC 62443-4-1 standards to ensure robust vulnerability management throughout the product life cycle
- Compliant with IEC 62443-4-2 standards to ensure component-level security as an extra layer of network protection



NPort 6000 Series Secure Terminal Servers

- Supports 802.1x security
- Set up devices easily with the Security Hardening Guide
- Supports HTTPS (TLS 1.2 embedded)/SSHv2/SNMPv3 security protocols



ioThinX 4510 Series Modular Remote I/O

- Set up devices easily with the Security Hardening Guide
- Safely upload your configuration files with HTTPS (TLS 1.2 embedded)
- Protect your data in SNMPv3 with SHA-256 cryptographic hash function and AES-128 encryption



Build Security Boundaries for Your Industrial Network

Network segmentation is key to enhancing your industrial network's performance and security. Instead of the traditional single-point firewall approach, Moxa solutions offer defense-in-depth flexibility, letting you build security perimeters between network segments to isolate critical OT networks, protect critical assets, or to secure remote access.

High-speed Boundary Defense

Don't let cyberthreats slow down your high-speed network operations. The EDR-G9010 Series industrial secure routers deliver 10-port Gigabit connectivity and robust security to help build network segments as the first line of defense, preventing threats from spreading to the rest of the network and protecting remote access and critical assets on your ICS networks.

EDR-G9010 Series 10-port Gigabit Industrial Secure Routers

- All-in-one firewall/NAT/VPN/router/switch
- 8 copper GbE ports and 2 SFP GbE ports
- Supports VRRP and Turbo Ring for routing and switching redundancy
- Deep Packet Inspection for Modbus TCP/UDP, DNP3, IEC 60870-5-104, and IEC 61850 MMS traffic filtering



Best-fit Scenario

Simple but Secure

The NAT-102 Series industrial NAT device provides an extra layer of security through IP address translation, which protects your machine networks against unauthorized access.

NAT-102 Series Industrial NAT Devices

- OT-friendly NAT functionality
- Automatic network access control
- Ultra-small footprint



Best-fit Scenario

Cloud-based Secure Remote Access

Moxa Remote Connect (MRC) is a cloud-hosted security platform that creates a secure virtual environment for remote services or enterprise collaboration.



MRC Client

A Windows-based application installed on laptops or computers to establish a secure link to the MRC Server.



MRC Server

A cloud-based server that manages scalable secure connections between MRC clients and MRC gateways.



MRC Gateways

Connect Ethernet-based machines to the MRC Server through AES-256-encrypted tunnels over the Internet.

Best-fit Scenario

Accelerate 2G/3G Migration With IIoT Boundary Security

Moxa's OnCell 3120-LTE-1 Series gateways accelerate 2G/3G migration into narrowband LTE communication while providing VPN and firewall security to form a protective barrier for IIoT applications, such as wide-area data collection from temperature sensors or street lights.

OnCell 3120-LTE-1 Series Industrial LTE Cat. 1 Cellular Gateways

- Supports global LTE connectivity including EU, US, and AU bands
- Supports regional certifications and cellular operators including Verizon, AT&T, PTCRB, FCC ID, RCM, and KC
- Serial/Ethernet-to-cellular flexibility
- -30 to 70°C operating temperature



Best-fit Scenario

Secure Substation Monitoring

A widely distributed power grid needs IEC 61850 certified VPN solutions to monitor the intelligent electronic devices (IEDs) in each remote substation. Moxa's EDR-G9010 Series works as a VPN firewall that provides a multi-layered defense and reduces costs through its multiple Gigabit connections.

- Full Gigabit VPN routing and switching
- IPsec for data encryption
- Firewall for local network segmentation and data protection
- Data filtering for DNP3, IEC 60870-5-104, and IEC 61850 MMS traffic
- IEC 61850-3 and IEEE 1613 certified

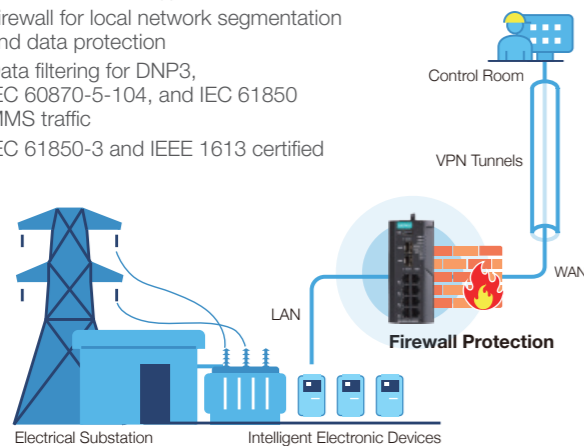

Application Site Boundary

Machine Network Defense

The compact NAT-102 fits perfectly inside most machines and creates a security boundary that restricts unwanted access through IP translation to protect the machine network.

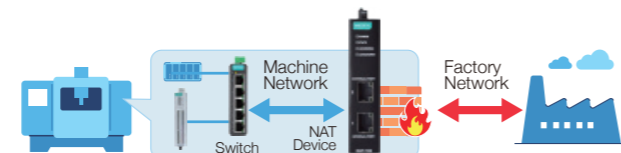

Machine Network Boundary

Remote Machine Maintenance Services

The MRC solution combines hardware and software measures to encrypt connections and create a virtual security boundary to safely perform remote machine maintenance.



Virtual Security Boundary

Remote Critical Data Acquisition

- IPsec, GRE, and OpenVPN for secure connections
- Dual-SIM and GuaranLink for reliable cellular connectivity
- WAN failover between cellular and Ethernet
- Low-power operation at 5 W during normal operation and 40 mW during standby
- ATEX, IECEx, and C1D2 certified for use in hazardous locations

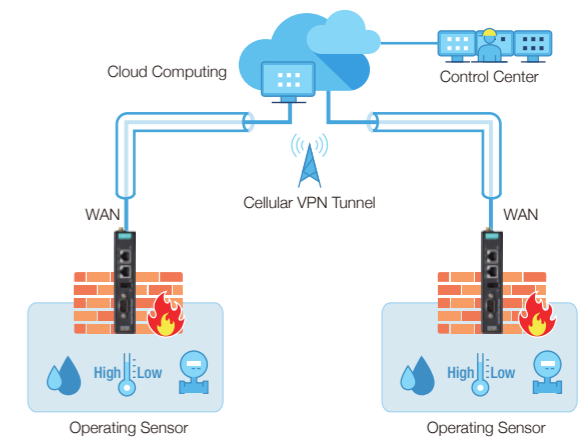

IIoT Network Boundary

	EDR-G9010	EDR-G903	EDR-G902	EDR-810	NAT-102	OnCell 3120-LTE-1	MRC-1002-T
WAN Connectivity	Ethernet					4G LTE	Ethernet or 4G LTE*
Ports	8 GbE + 2 GbE SFP	3 GbE Combo	1 GbE + 1 GbE Combo	8 FE + 2 GbE SFP	2 FE	2 FE + 1 Serial	2 FE
Layer 2 Switching	Yes	-	-	Yes	-	-	-
VPN	IPsec VPN	IPsec VPN, OpenVPN			-	IPsec VPN, GRE, OpenVPN	OpenVPN
NAT	1-to-1, N-to-1, Port forwarding						-
Firewall	DDoS, Ethernet protocols, ICMP, IP address, MAC address, Ports				IP address, MAC address, Ports	Ethernet protocols, ICMP, IP address, MAC address, Ports	Service-based and allowlist remote access control

*MRC-1002-T: Ethernet only; MRC-1002-LTE-EU/US/JP-T: LTE only.

Preemptive Defense-in-depth Beyond the Perimeter

The rise of both IT/OT convergence and remote work coincides with increasingly evolving cyberthreats. Therefore, up-to-date security features incorporating intrusion detection, prevention, mitigation, and perimeter protection are a must-have in mission-critical industrial networks to ensure operational uptime. However, for both IT/OT convergence and remote work, it is not always so straightforward to define a network's boundary for perimeter security purposes.

To preempt ever-present cyberthreats, Moxa combines OT-centric firewall capabilities with MXsecurity management to help you detect cyberthreats and prevent them, ensuring secure and continuous operations.

OT-enabled Security to Ensure Continuity

Deep Packet Inspection

As many industrial protocols are vulnerable by design, the EDR-G9010 extends deep packet inspection (DPI) to the following OT protocols to filter content and help mission-critical infrastructure fend off malicious traffic:

- Modbus TCP/UDP
- DNP3
- IEC 60870-5-104
- IEC 61850 MMS

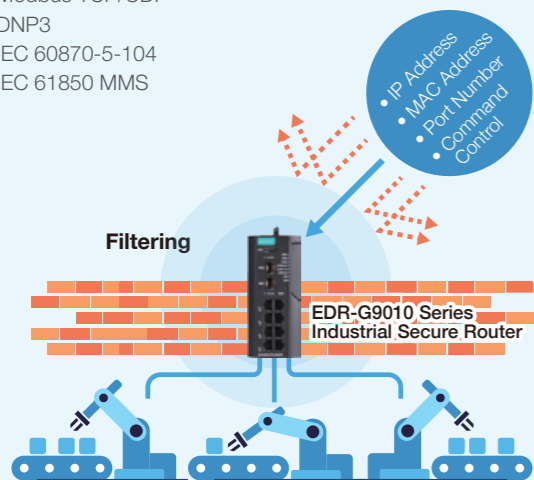

For overall OT network protection, the EDR-G9010 secure router provides Gigabit-speed filtering of allowed OT protocols and pattern-based threat modeling. Additional features include robust and flexible firewall isolation, IP translation, and remote VPN encryption. The EDR-G9010's fast boot time and Layer 2/Layer 3 redundancy further help ensure your network's availability.

Intrusion Detection and Prevention

For continuous protection against threats, the EDR-G9010 integrates intelligent IPS features that perform pattern-based detection and block known attacks.

Proactive Virtual Patching

The IPS firewall requires no downtime to apply virtual patches for vulnerabilities in legacy operating systems, application software, and industrial devices such as PLCs.

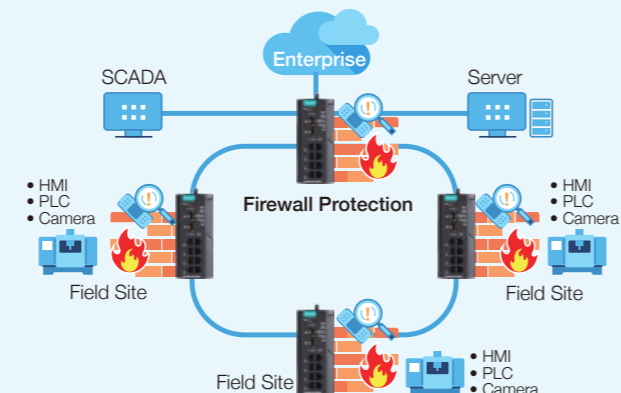

Real-time Visibility for Protection Against Threats

MXsecurity provides centralized visibility and security management to easily monitor and identify cyberthreats. Most importantly, this industrial network security management suite prevents misconfiguration of device security when fending off these threats. MXsecurity translates complex network activity and intelligence about threats into real-time visibility of the network's cybersecurity status. It also provides actionable impact management to combat cyberthreats. With real-time dashboard visibility, MXsecurity helps you track and react immediately to OT network security threats.

Centralized Management

Centrally manage and monitor your firewall deployments for better administration and maintenance.



Real-time Monitoring

Complete visibility showing real-time network activity and alerting you about threats.



Unified Mass Deployment

Unified deployment of firewall policies, firmware upgrades, and signature updates ensures your network protection uses the latest security intelligence.



Logging and Alert Notifications

Automatically collects security logs and sends notifications based on policies.



Proactive Defense Against Cyberthreats for Industrial Automation

The Best Fit for Critical Infrastructure

EDR-G9010 Series
All-in-one Secure Routers
(Router/Switch/NAT/VPN/Firewall/IPS*)

MXsecurity
Industrial Security Management Software**

- Deep packet inspection (DPI) for OT-centric application protocol content filtering
- Built-in IEC-62443-4-2 compliant security features
- Unified mass deployment of security configurations and virtual patch updates for legacy systems and applications
- Field-proven reliability with diverse industry certifications



IEEE 1613 or IEC 61850 certifications required for power-utility infrastructure



ATEX and Class I Division 2 certifications required for hazardous locations



IEC 60945 and DNV certifications required for maritime applications



NEMA TS2 certification required for traffic control signal systems

VS.

The Best Fit for Factory Automation

IEC-G102-BP Series
Industrial IPS/IDS

IEF-G9010 Series
Industrial IPS Firewall

Security Dashboard Console
Security Management Software

- Fine-grained Layer 2 to Layer 7 firewall policy with IPS capabilities
- Bump-in-the-wire installation without affecting the network
- Automatically deploy virtual patches without disrupting operations
- Industrial reliability to withstand harsh factory environments

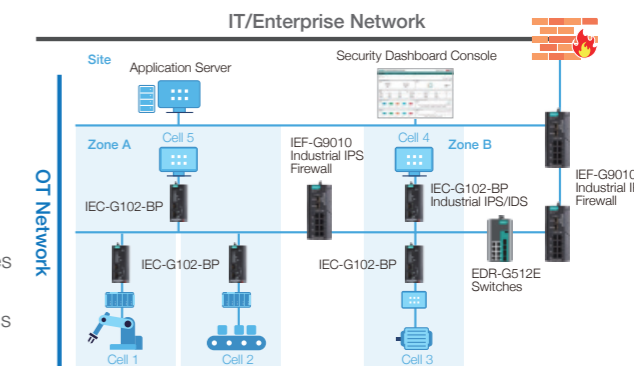

*IPS functionality will be available in Q3, 2022. **MXsecurity will be available in Q3 2022.

Gain More Visibility to Boost Network Availability

MXview One is a scalable industrial network management platform that helps OT engineers simplify management of converged IT/OT networks. With comprehensive, real-time visibility of wired, wireless, and IEC 61850 substation networks, MXview One optimizes operations and availability throughout all stages of network deployment, management, and maintenance.



Smart Visibility for Faster Responses

Ensuring uptime is everything. MXview One provides real-time network visibility to enable swift troubleshooting without the need for IT expertise. The information-packed dashboards offer full visibility of topologies, network traffic, events, roaming history, and GOOSE status, all of which help simplify network management, improve response times, and optimize network uptime.

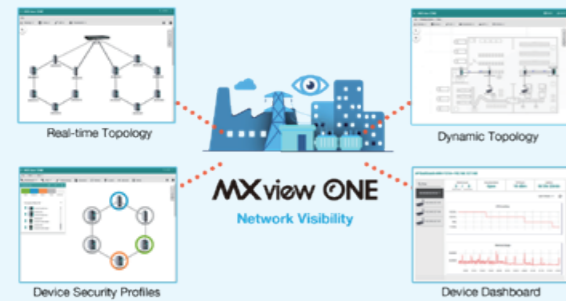

Single-pane Monitoring of Your Operations

MXview One is designed for managing IT/OT converged networks connecting complex machines and systems. To bridge management between these systems, MXview One supports a web widget and RESTful API on the northbound interface, both of which can help embed MXview One into SCADA systems and other web-based applications to implement single-pane-of-glass management with integrated network monitoring.

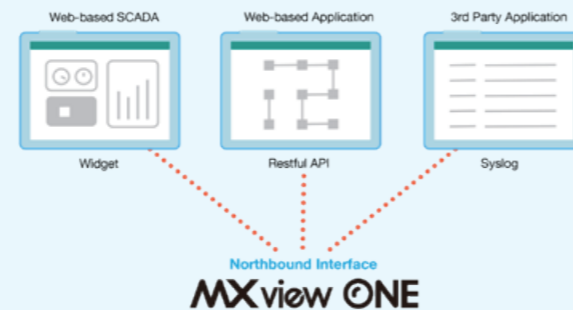

Management Add-ons Tailored for Substation and Wireless Network Monitoring

MXview Power New

Extended Visibility to Enhance Power Network Resilience

Built for monitoring critical IEC 61850 power networks, MXview Power extends real-time visibility beyond industrial Ethernet networks to include IED statuses, GOOSE messages, and the redundant connections of PRP/HSR networks. Backed with industry experience and expertise, these features are designed to help bolster power network resilience.



MXview Power

MXview Wireless

Dynamic Monitoring and Efficient Troubleshooting

MXview Wireless delivers full visibility of dynamic Wi-Fi connections between APs and clients to help ensure reliable wireless communication. The Roaming Playback feature lets OT engineers review a client's history to identify and troubleshoot network issues.

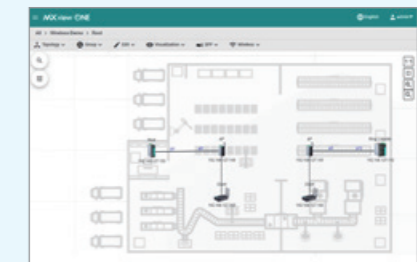

MXview Wireless

MXview One: A next-generation industrial network management platform to optimize your industrial network operations and resilience

► Challenges

Deployment

Deploying devices one by one is both time-consuming and prone to errors.

Operation

Monitoring network health and traffic while responding to events is resource-intensive.

Maintenance

Network backups require repetitive manual tasks that increase maintenance time, costs, and the risk of errors.

Troubleshooting

Unstructured troubleshooting leads to delays and incorrect network diagnoses, wasting time and resources.

► MXview One Solutions

Faster Mass Deployment

MXconfig speeds up network deployment through group configuration and duplication, and link sequence detection.

MXconfig

Industrial Network Configuration Tool

- Configuration is 10x faster than deploying devices one by one
- Link sequence detection eliminates manual configuration errors
- Security Wizard for device security setup and updates



Smart Visualization

MXview One provides a real-time visual overview of the network topologies that allows engineers to monitor and manage networks more easily.

MXview One

Next-generation Scalable Industrial Network Management Platform

- Automatic topology visualization
- Security View for checking the security level of network devices
- Real-time dashboard with a complete network summary
- Easy integration through RESTful API, web widget, and syslog for single-pane monitoring with other IT/OT applications
- Scheduled configuration backups

One-click Backup

MXview One's Configuration Center supports one-click bulk configuration backups, scheduled backups, firmware upgrades, and customizable rollbacks for easier maintenance.

- SFP Fiber List for fiber link status and warnings
- Comprehensive reports for network and device performance analysis



Quick Diagnostics

MXview One supports event searches and playback functions for more efficient troubleshooting.

MXview Power Add-on

- Automatic concise visibility of PRP/HSR dual LAN topologies
- Instant visibility of GOOSE control messages for better troubleshooting
- Automatically scans and detects unauthorized IEDs for preemptive protection

MXview Wireless Add-on

- Dynamic topology view for Wi-Fi networks
- Client roaming playback for troubleshooting
- Device dashboards and performance charts for wireless devices

Redefine OT Reliability With Hardened Security

As industrial networks continue to expand from small, local sites to larger and remote sites, Moxa's industrial rackmount switches provide more than just 10GbE/GbE performance. Featuring 24 to 52-port modular flexibility with copper, fiber, and PoE interfaces, as well as power module options, these switches ensure scalable, reliable, and secure data aggregation from the edge to the core in demanding environments.

New Additions With Certified Security



The RKS-G4000 Series modular switches redefine network reliability. Built from the ground up to be secure-by-design and IEC 62443-4-2 certified, these switches enhance network security with up to 28-port full Gigabit modular connectivity.

The RKS-G4000 offers field-proven reliability with Layer 3 and Layer 2 options and a wide selection of copper, fiber, and PoE interface modules to meet complex network requirements.

RKS-G4000 Series Layer 2/3 28 GbE/24 FE + 4 GbE Rackmount Switches

- Up to 28 GbE ports with modular copper, fiber, PoE options
- 300 W PoE budget with up to 90 W output per port
- IEC 62443-4-1/-4-2 certified security features
- IEC 61850-3 and IEEE 1613 certified
- Hardware-based IEEE 1588 PTP for high-precision time synchronization
- Redundant power supplies with HV/LV options

10GbE Backbone Convergence

The ICS Series industrial rackmount switches enable 10GbE/GbE backbone convergence and scalability to simplify your edge-to-core network infrastructure.

- Up to four 10GbE and 48 GbE uplinks
- Supports Turbo Ring and Turbo Chain for Gigabit redundancy under 50 milliseconds
- Supports Turbo Chain to create unlimited redundant network expansions without reconfiguration or disruption

Robust Reliability

Moxa's rackmount switches can handle large numbers of links and high-volume data aggregation in harsh conditions, increasing uptime and reducing the total cost of ownership (TCO).

- High EMI shielding
- High MTBF with no fan or heater needed
- Hot-swappable modules (ICS modular switches only)
- Dual isolated power supplies

IACS-level Device Security

All Moxa's industrial rackmount switches are built with IACS (Industrial Automation Control System) security features that are available via firmware updates.

- Built-in security features based on the IEC 62443 standard
- Device-based security for data protection and access control
- Supports MXview One for device security profiling and status monitoring

Choose Reliability

Comparison of Rackmount Ethernet Switches

	Moxa Switches	Commercial Switches
ESD	+/- 8 kV	+/- 4 kV
Radiated RFI	10 V/m @ 80 MHz to 1 GHz	3 V/m @ 80 MHz to 1 GHz
Surge	2 kV	1.5 kV
EFT	1 kV	0.5 kV
Operating Temperature	-10 to 60°C, -40 to 75°C	0 to 40°C
Heat Dissipation	Fanless	Fan
Industrial Certifications	CE/FCC, EN/UL 61010-2-201, DNV/ABS/LR/NK*, IEC 61850-3/IEEE 1613**, EN 50121-4	CE/FCC

*IKS-6728A/6726A only. **RKS-G4000 only.

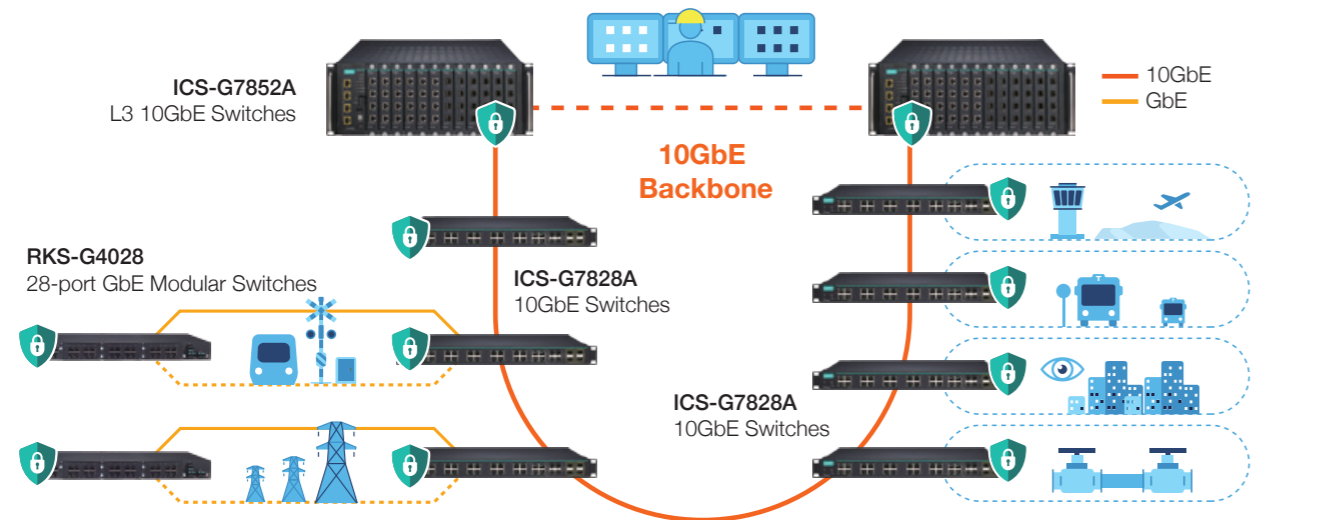

Use Case

10GbE Backbone for Tram Station Surveillance

An urban tram system required a reliable network backbone between 15 stations to ensure operational safety and security.

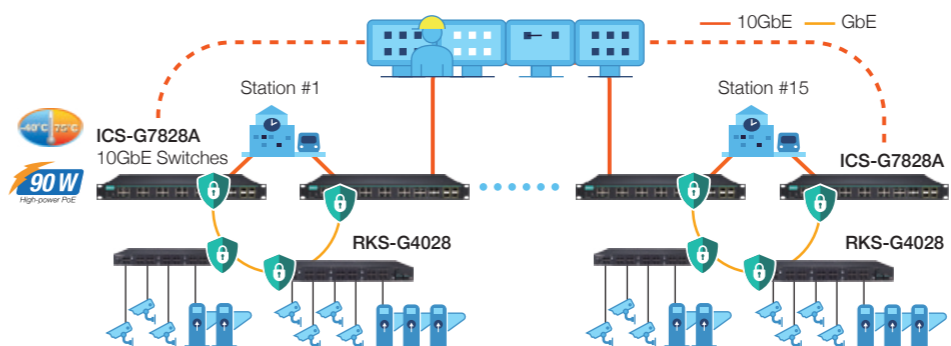

Network Requirements

- High-capacity data aggregation and long-distance transmissions
- Network resilience for operational safety and security
- Flexible network deployment and expansion to outdoor environments

Why Moxa

- ICS-G7828A Series switches provide 10GbE fiber uplinks for high-volume data aggregation from remote stations
- RKS-G4028 Series switches deliver up to 24 PoE links to power IP cameras for simplified installation and less cabling
- Supports Turbo Ring and Turbo Chain for flexible and redundant ring expansion and Gigabit recovery under 50 ms

	ICS-G7852A/G7850A L3 10GbE	ICS-G7828A/G7826A L3 10GbE	ICS-G7848A L3 Full GbE	RKS-G4028-L3* L3 Full GbE	IKS-G6824A L3 Full GbE
10GbE Ports	4/2	4/2	-	-	-
GbE Ports	Up to 48	24	Up to 48	Up to 28	24
FE Ports	-	-	-	Up to 24	-
PoE Ports	Up to 48 GbE	-	Up to 48 GbE	Up to 24 GbE/FE	-
Operating Temp.	-10 to 60°C	-40 to 75°C	-10 to 60°C	-40 to 75°C	-40 to 75°C

*The RKS-G4028-L3/RKS-G4028 Series will be available in Q3 2022.

	ICS-G7752A/7750A L2 10GbE	ICS-G7528A/7526A L2 10GbE	ICS-G7748A Full GbE	RKS-G4028* Full GbE	IKS-G6524A Full GbE	IKS-6728A/6726A Best Value
10GbE Ports	4/2	4/2	-	-	-	-
GbE Ports	Up to 48	24	Up to 48	Up to 28	24	4/2
FE Ports	-	-	-	Up to 24	-	Up to 24
PoE Ports	Up to 48 GbE	-	Up to 48 GbE	Up to 24 GbE/FE	-	Up to 24 FE (IKS-6728A only)
Operating Temp.	-10 to 60°C	-40 to 75°C	-10 to 60°C	-40 to 75°C	-40 to 75°C	-40 to 75°C

Turn Connectivity Into Operational Advantages

Industrial networks need to keep up with increasing complexity, speed, and scale to meet changing demands and add value to provide a competitive edge.

The MDS-G4000 Series modular switches are designed to help turn every challenge into an opportunity, thanks to their wide variety of Ethernet and power modules that you can freely mix and match as needed. The upcoming MDS-G4000-4XGS Series* features 10GbE ports to facilitate large-scale IT/OT convergence.

Standards-based security and industry-certified reliability are built into all modules to support sustainable operations. Meanwhile, the hot-swappable modules can be replaced without causing any interruptions or downtime.

With a variety of power, interface, and installation options, the MDS-G4000 Series lets you customize your network to meet your needs of today and tomorrow.



*The MDS-G4000-4XGS/MDS-G4000-L3-4XGS Series will be available in Q3 2022.

10GbE IT/OT Convergence for Mining Automation

Underground mines rely on high-speed and robust network infrastructure to support real-time control and monitoring systems to ensure overall operational continuity, safety, and productivity. The MDS-G4000 Series modular switches feature futureproof performance, industry-proven reliability, and extensive flexibility to accommodate large, complex, and mission-critical mining network communications.

MDS-G4000/MDS-G4000-L3 Series Industrial Layer 2/3 10GbE/GbE/FE Modular Managed Switches



Network Scalability

- Layer 3 routing interconnects multiple LAN segments
- Layer 2 switching supports Turbo Chain for uninterrupted and unlimited sub-ring expansions



Performance Flexibility

- 10GbE/GbE/FE port speed options
- 4-port RJ45, SFP, and PoE interface modules
- Up to 6 module slots for 12/20/28 ports



Availability

- Supports VRRP for routing redundancy
- Supports Turbo Ring and Turbo Chain for Gigabit redundancy under 50 ms
- Dual isolated redundant power units



Security

- Built-in device security based on the IEC 62443 standards
- Role-based access control
- MAC-based IP assignment



Continuity

- Hot-swappable modules for uninterrupted operations
- Power outage protection during firmware upgrades



Reliability

- Die-cast design with superior vibration and shock resistance
- Diverse industry certifications

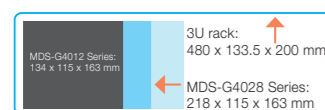

Installation Flexibility

- Ultra-compact to fit in most cabinets
- Supports DIN-rail, rack*, and wall-mounting options

*Rack-mounting is available with an optional installation kit.

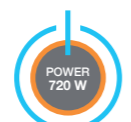

Smart PoE Delivery

- Up to 24 PoE links with 36 W output per port and a 720 W budget
- Built-in Smart PoE firmware for easy PD links, diagnostics, and monitoring



OT-friendly Usability

- HTML5 dashboards for device summary, smart search, and configuration
- Supports MXview One for intuitive network management

Network Requirements

- Simultaneously support multiple applications
- Non-stop communications to ensure operational safety, continuity, and productivity
- Fast responses to critical events
- Maximized network flexibility to support additional network services
- Hardened reliability and security to minimize downtime and maintenance

Why the MDS-G4000 Modular Switches

Futureproof Scalability

- Build 10GbE network backbones to aggregate massive data flows from underground subsystems
- Interchangeable GbE/FE modules with RJ45/SFP/PoE interface options to connect different devices

Constant Availability

- Failover with millisecond-fast redundancy for maximum uptime
- Hot-swappable modules for maintenance without downtime
- Built-in security against unauthorized access

Robust Reliability

- Die-cast design with superior vibration and shock resistance
- C1D2 ATEX certified for use in hazardous locations**

Simplified Operation

- HTML5 dashboard for enhanced network visibility and control
- Supports MXview One network management for real-time alerts and troubleshooting

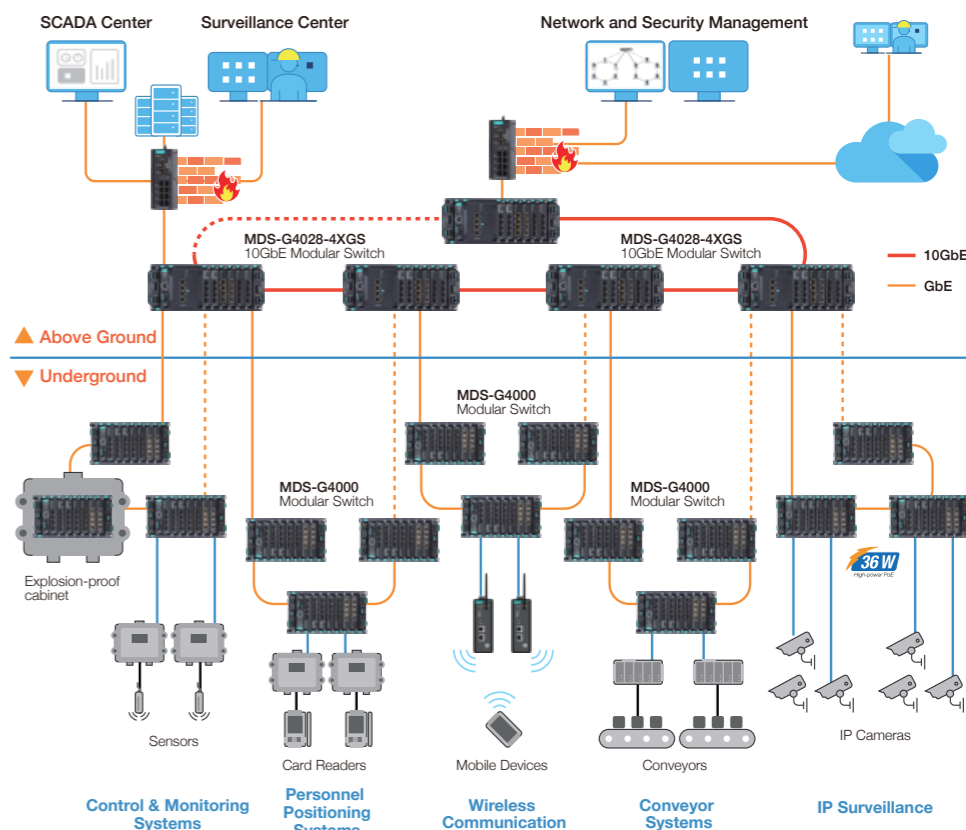

	MDS-G4000	MDS-G4000-L3	MDS-G4000-4XGS*	MDS-G4000-L3-4XGS*
Layer	Layer 2	Layer 3	Layer 2	Layer 3
No. of Ports	12, 20, 28	12, 20, 28	12, 20, 28	12, 20, 28
10GbE Ports	-	-	4	4
GbE Ports	12, 20, 28	12, 20, 28	8, 16, 24	8, 16, 24
Fiber Ports	Up to 24	Up to 24	Up to 28	Up to 28
Fiber Type	SFP			
Industrial Certifications	C1D2, ATEX Zone 2, IEC 61850-3, IEEE 1613, EN 50121-4, NEMA TS2		IEC 61850-3, IEEE 1613, EN 50121-4, NEMA TS2	

*Available in Q3 2022. ** Available for the MDS-G4000/MDS-G4000-L3 Series only.



Built-in Scalability to Strengthen Your Network Resilience

Industrial networks need to evolve to support resilient operations. When integrating new network components, even small changes can face unexpected challenges, such as limited installation space.

The EDS-4000/G4000 Series industrial managed Ethernet switches consist of 68 models that feature scalable functionality compressed into one unified form factor, allowing you to effortlessly expand your network to meet changing requirements. Adding more bandwidth or more PoE power is now easier than ever. More importantly, EDS-4000/G4000 switches are certified for the latest security and industry standards to ensure robust network resilience.



EDS-4000/G4000 Series Industrial Managed Ethernet Switches

- 68 models with 8 to 14 ports
- 2.5GbE/GbE/FE/PoE port speed options
- Supports Turbo Ring and Turbo Chain for millisecond-level redundancy
- Security compliant with the IEC-62443-4-2 standard
- Diverse industry certifications
- Compact size of 55 x 140 x 122.5 mm



OT Security Benchmark

The EDS-4000/G4000 Series switches are the world's first IEC 62443-4-2 compliant Ethernet switches certified by IECCE. With a portfolio of 68 models, the EDS-4000/G4000 switches provide a secure infrastructure with versatile functionality to connect and protect your industrial operations.

Futureproof Performance

The EDS-4000/G4000 switches deliver unprecedented performance to meet unpredictable network requirements. These switches support up to 14 ports with a variety of interface speeds and types such as 2.5GbE uplinks, 90 W PoE, and SFP for long-distance connectivity.

Smart Usability

The intuitive user interface streamlines and simplifies network management. LED indicators on both sides help identify the device status while the unique rotatable, replaceable power module helps speed up installation and maintenance.

Industry-proven Reliability

Network reliability remains a top priority for industries that can't afford unplanned downtime. The EDS-4000/G4000 switches are certified for multiple industry standards to ensure reliability in demanding industrial applications.



Built-in Futureproof Features

- Up to six 2.5GbE uplink ports
- 2.5GbE fiber connections up to 45 km
- 802.3bt PoE++ with up to 90 W per port
- Supports 5 GbE uplink or dual rings through port aggregation
- Rotatable power modules to adapt to dynamic field applications



	EDS-4008 Series	EDS-4009 Series	EDS-4012 Series	EDS-4014 Series	EDS-G4008 Series	EDS-G4012 Series	EDS-G4014 Series
2.5GbE Ports	-	-	-	2	-	Up to 4	6
GbE Ports	Up to 2	-	4	4	8	Up to 12	8
FE Ports	Up to 8	Up to 9	8	8	-	-	-
90 W PoE Ports	Up to 4	-	Up to 8	-	-	Up to 8	-
Operating Temp.	-10 to 60°C, -40 to 75°C (-T models)						
Power Input	-LV models: 12/24/48 VDC; -HV models: 110/220 VDC/VAC						
Industrial Certifications	IEC 61850-3, IEEE 1613 (Class 1), DNV, ABS, NKK, LR, EN 50121-4, NEMA TS2* ATEX**, Class I Division 2**, IECEx**						

*Available for selected models only. **Certification in progress.



EDS-400A/500A/500E Series Optimized for Reliability and Productivity

Moxa's rugged DIN-rail managed switches all feature robust durability and failover redundancy to enable uninterrupted connectivity required for industrial applications. The EDS-400A/500A/500E Series switches provide diverse features but share a common set of availability, reliability, and security functions to enable easy integration, bolster resilience, and improve efficiency.



Security

- Advanced security features based on the IEC 62443 standard (EDS-500E Series only)
- Supports MXview One to easily manage the security status of network devices



SCADA Integration

- Supports multiple industrial-automation (IA) protocols for easy SCADA and PLC network integration



Constant Availability

- Millisecond-level failover recovery
- Unlimited subnetwork expansion
- Live node expansion without network interruptions
- Large savings on cabling costs

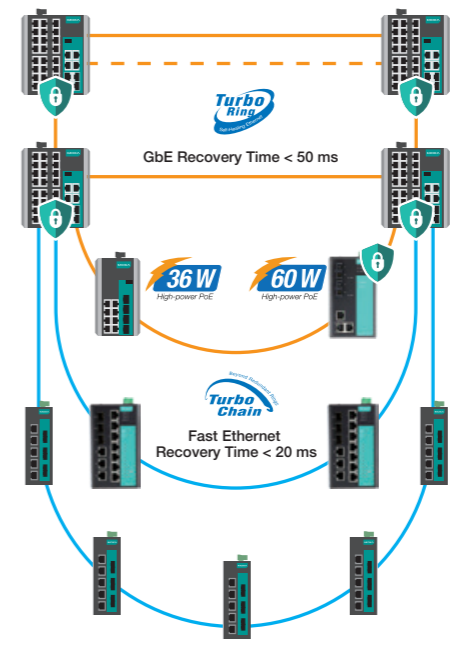

Smart PoE

- Up to 60 W PoE+ output
- Built-in Smart PoE for remote PD links, diagnostics, and failure recovery



Industrial Reliability

- High EMI resistance
- Diverse industry certifications
- Fanless and wide operating temperature



Simplified Management

- Error-free and time-saving mass configuration
- Live topology monitoring and instant alerts



	EDS-G500E Series	EDS-500E Series	EDS-500A Series	EDS-400A Series
No. of Ports	8, 12, 16	10, 18, 28	5, 8, 10, 16, 18	5, 8
GbE Ports	8, 12, 16	3, 4, 4	Max. 3*	-
Fiber Ports	Max. 4*	3, 4, 4	Max. 2*	Max. 3*
Fiber Type	SFP	SFP	ST, SC, SFP	ST, SC
PoE Ports	Up to 8 (EDS-G512E only)	Up to 4 (EDS-P506E-4PoE only)	Up to 8 (EDS-P510A-8PoE only)	-
PoE Output	36 W	Up to 60 W	36 W	-
Industrial Certifications	C1D2/ATEX Zone 2, IEC 61850-3, IEEE 1613, DNV, ABS, LR, NK, EN 50121-4, NEMA TS2		C1D2/ATEX, DNV, EN 50121-4, NEMA TS2	

*Available for selected models only.

Reliable and Easy Network Expansion

For industrial applications, reliable and rapid network expansion is a must for ensuring safety and productivity, especially in demanding environments such as data collection in hazardous areas or when planning new production lines in automated factories.

To keep up with changing connection requirements, the EDS-2000 Series unmanaged switches offer 5 to 18-port options in an extra-small form factor. Combined with plug-and-play installation and reliability features, the EDS-2000 Series enhances your network operations while also saving you time and effort.

Enjoy the plug-and-forget reliability of the EDS-2000-EL switches, which have been put through a six-month accelerated life-cycle test that showed the EDS-2000-EL Series can reliably operate 24/7 at extreme temperatures.



Application Notes

Field Asset Monitoring Along Pipeline Cabinets

Network Requirements

- Rugged network devices suitable for hazardous areas
- Instant warnings for on-site monitoring
- Enhanced noise resistance to transfer data from I/Os and EMS cabinets to a local network console

Moxa Solutions

EDS-2018-ML Series 16+2G-port Unmanaged Switches

- Relay alarm for power failure or link break warnings
- QoS guarantees high priority for critical data
- NEMA TS2, IECEx, ATEX, C1D2 certified

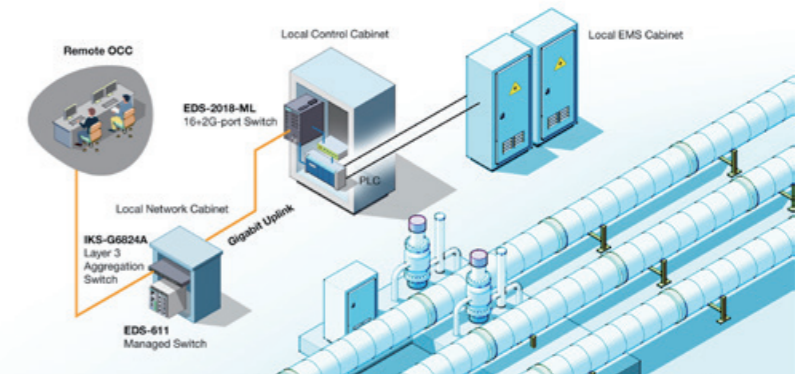

Reliable Data and Image Collection From ETC Gantries

System Requirements

- Durable devices that work reliably in open road environments
- Long-distance connections of over 100 meters to send video streams and sensor data to roadside cabinets
- Easy installation and long-lasting reliability to minimize maintenance time on the gantry

Moxa Solutions

EDS-2010-ML Series 8+2G-port Unmanaged Switches

- Two Gigabit combo ports for long-distance fiber uplinks
- DIP switch-enabled settings and relay alarm minimize on-site configuration and maintenance efforts
- -40 to 75°C operating temperature
- NEMA TS2 certified

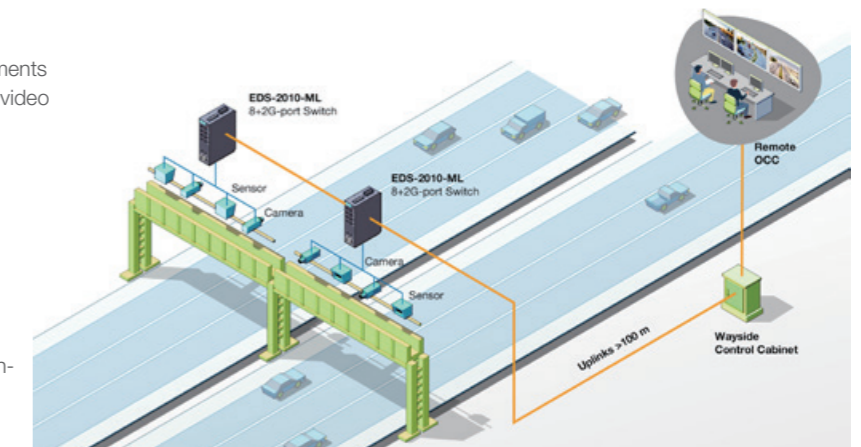

EDS-2000-EL/ML Series

Industrial Unmanaged Ethernet Switches

Flexibility

- Small, compact form factor
- 5 to 18 ports
- Gigabit combo ports for versatile uplinks*

Easy Deployment

- Enable QoS and BSP via DIP switch
- Multiple DIN-rail mounting options*

Reliability

- Power redundancy*
- -40 to 75°C operating temperature
- Full range of industry certifications*

Features and Benefits

Ultra-compact
Extra-small design for easy placement into control cabinets

Gigabit Combo
Up to 2 Gigabit combo ports for fast and flexible uplinks*

Dual Power
Redundant 9.6 to 60 VDC input for higher reliability*

Relay Alarm
Automatic warnings for power and port failures*

Low Latency
Microsecond-level latency for faster Manufacturing Execution System (MES) response times

Data Efficiency
Enhanced data efficiency via QoS and BSP functions

Relay Alarm
Automatic warnings for power and port failures*

Flexible Deployment
Multiple mounting options for flexible DIN-rail installation*

Certified Reliability
Industry-certified for use in mission-critical applications*

*Only available for the EDS-2000-ML Series.



	EDS-2000-EL Series	EDS-2000-ML Series	EDS-200A Series	EDS-G200/G300 Series
Features	<ul style="list-style-type: none"> • Extra-small size • QoS, BSP via DIP switch • Metal/plastic housing 	<ul style="list-style-type: none"> • High port density • QoS, BSP via DIP switch • Relay output warnings 	<ul style="list-style-type: none"> • Redundant dual 12/24/48 VDC inputs 	<ul style="list-style-type: none"> • Fiber Gigabit connections • Jumbo frames for enhanced performance
GbE Ports	-	2	-	5/8
FE Ports	5/8	10/16/18	5/8	5/8
Fiber Ports	Up to 1*	Up to 2	Up to 2*	Up to 2*
PoE Ports	-	-	Up to 4 PoE+ (EDS-P206A-4PoE only)	Up to 4 PoE+ (EDS-G205A-4PoE only)
Operating Temperature	-10 to 60°C, -40 to 75°C (-T models)			
Industrial Certifications	CE/FCC, UL 61010-2-201, EN 62368-1 (LVD), CISPR (EN 55032)	C1D2, ATEX, IECEx, DNV, EN 50121-4, NEMA TS2, UL 61010-2-201	C1D2, ATEX, IECEx, DNV, ABS, LR, NK, EN 50121-4, NEMA TS2, UL 508	

*Available for selected models only.

Ultra-compact Design

For easy deployment into cabinets

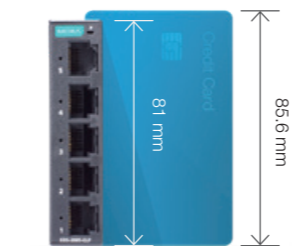

EDS-2005-EL Switch vs. Credit Card

Proven Track Record

Moxa's wide array of industrial unmanaged switches provide rock-solid reliability and can withstand extreme conditions, earning the confidence and satisfaction of global customers through thousands of long-term deployments around the world.

Rich Options

- Gigabit, copper, fiber, and PoE options
- Up to 36 W output per PoE port
- QoS and BSP functions for traffic efficiency
- Redundant power inputs
- -40 to 75°C operating temperature
- Diverse industrial certifications

Broad Unmanaged Switch Portfolio



Simplify IA Network Integration

Network complexity and environmental constraints hinder the efficiency of industrial network deployment and maintenance for most industrial automation (IA) engineers, even when only dealing with minor changes.

Moxa's smart switches simplify daily tasks for IA engineers by seamlessly integrating SCADA and PLC networks with a one-click industrial protocol setup. Users can quickly configure the IA protocol settings to enable interoperability and integration with SCADA/HMI systems using the web GUI or rotary DIP switches.

As a result, IA engineers such as machine builders and automation engineers can monitor the control system and network status from their SCADA/HMI systems and react quickly to minimize downtime.

With their simplified protocol configuration, flexible mounting design, easy-to-use interface, and slim form factor, the SDS-3000 Series industrial smart switches are the perfect fit for control cabinets in any smart manufacturing application.

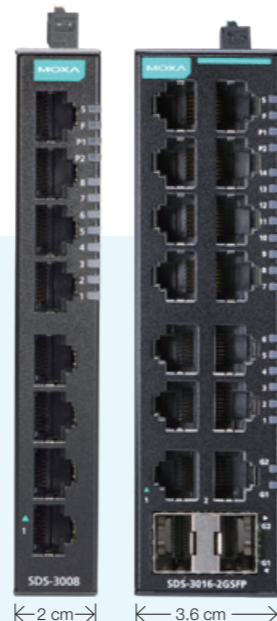

SDS-3008/3016 Series 8/16-port Smart Switches



OT Management

- One click to enable SCADA/HMI/NMS interoperability and integration
- Supports EtherNet/IP, PROFINET, and Modbus TCP protocols



Robust Reliability

- Security features based on the IEC 62443 standard
- Supports RSTP/STP/MRP (Client) network redundancy
- -40 to 75°C operating temperature (-T models)



Ease of Use

- One-page dashboard GUI for easy configuration and diagnostic reports
- Rotary DIP switches for IA profile settings (SDS-3016 Series only)
- Compatible with Moxa's ABC-02 configuration backup and restoration tool

Use Case

Overhead Transfer System

An acclaimed automotive manufacturing facility in South Africa needed an overhead transfer system (OTS) to move vehicles through production processes.

Network Requirements

- Reliable networks to ensure non-stop operations
- Support for monitoring through a SCADA/HMI
- Compact enough to deploy into confined spaces

Why Moxa Smart Switches

- One-click configuration of EtherNet/IP settings to achieve fast configuration and flexible deployment
- The switch status can be monitored from SCADA and HMI systems
- An integrated, single-page console simplifies operation and monitoring
- Compact design and flexible mounting options make them easy to install in small cabinets

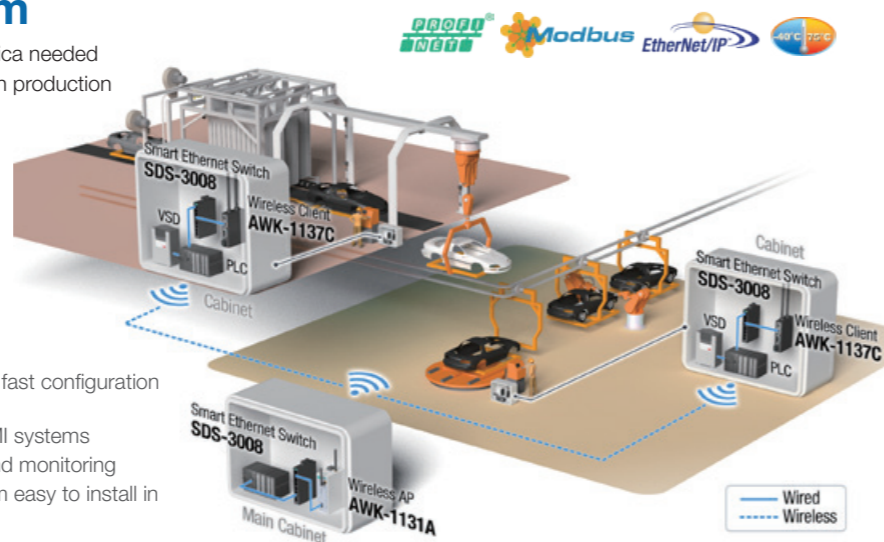

Transform Your Broadband Experience

As demand for high-capacity data collection continues to grow, fiber-optic connections enhance your broadband experience by providing higher speeds over longer distances and better noise immunity than copper-wired networks.

Moxa offers industrial media converters that provide copper-to-fiber Gigabit-speed extensions of up to 120 km over single-mode fiber in harsh conditions.

Moxa's Ethernet-to-fiber media converters feature innovations that include link fault pass-through, relay output, industrial-grade reliability, and a compact design that can withstand industrial environments.

Both the IMC-101G and IMC-21GA fiber converters are perfect for megapixel machine vision inspection, public IP surveillance, and outdoor applications that require Gigabit throughput and EMI immunity with fewer hops, regardless of distance.

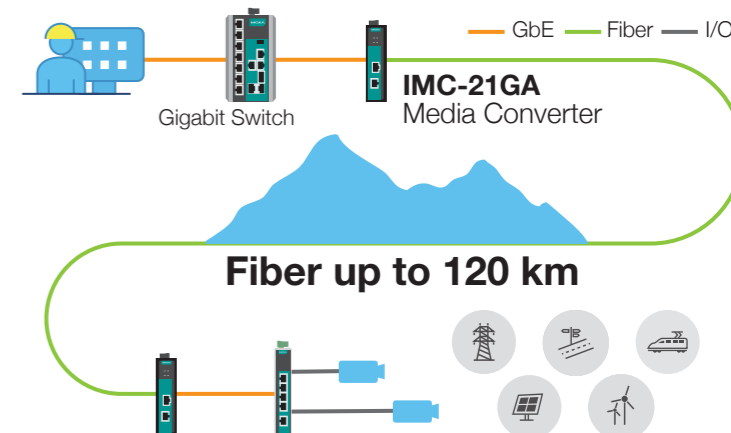

Long-haul Options

- The IMC-21GA supports Gigabit single/multi-mode models with an SC connector and SFP slot for flexible deployment from 0.5 to 120 km
- The IMC-101G supports single-mode fiber for data transmissions up to 120 km



Easy Maintenance

- Link fault pass-through to easily trace network link failures
- Compact size and DIN-rail mounting for easy installation
- LED indicators for easy maintenance



Industrial Reliability

- Power failure and port break alarms by relay output
- Redundant power inputs
- -40 to 75°C operating temperature
- Industrial certifications for hazardous locations

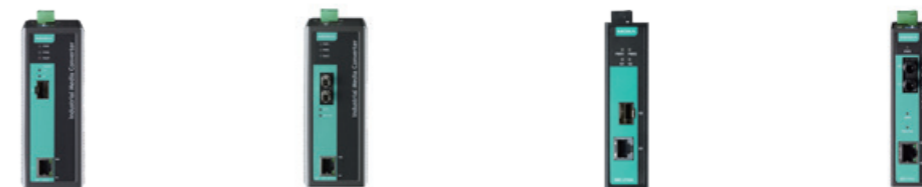

	IMC-101G	IMC-101	IMC-21GA	IMC-21A
Ethernet Ports	1 GbE	1 FE	1 GbE	1 FE
Fiber Ports	1000Base SFP slot	100BaseFX (SC or ST)	1000BaseSX/LX or 100/1000Base SFP slot	100BaseFX (SC or ST)
Single-mode Transmission Distance	Up to 120 km	Up to 40 km	Up to 120 km	Up to 40 km
Dual Power Inputs	12 to 45 VDC		12 to 48 VDC	
Operating Temperature	0 to 60°C, -40 to 75°C (-T models)		-10 to 60°C, -40 to 75°C (-T models)	
Industrial Certifications	UL 508, C1D2, ATEX Zone 2, IECEx	UL 508, UL 60950-1 C1D2, ATEX Zone 2, IECEx, DNV	UL 60950-1	



Building Field-proven and Error-free Wireless Networks

Wireless connections help you avoid wiring hassles but raise concerns about the availability, security, and reliability of the network. Moxa's AWK Series industrial Wi-Fi solutions deliver worry-free wireless connections, making sure you don't have to deal with unreliable wireless connections due to interference, weak signals, or slow failovers.

The AWK Series products provide field-proven wireless connectivity and innovative software features to optimize your wireless network for reliability, availability, and security. Most of the AWK products come with the AeroMag zero-configuration tool to optimize your WLAN operations, from deployment to operation to troubleshooting, with just a few clicks. The MXview Wireless add-on module for the MXview One industrial network management software offers real-time visibility of dynamic wireless connections and link changes for efficient monitoring and troubleshooting.

Combining built-in device security and hardened designs for extreme operating conditions, Moxa's AWK Series provides field-proven Wi-Fi connectivity to meet the requirements of a variety of mission-critical applications.



Availability

- Turbo Roaming for fast handovers under 150 ms
- AeroMag for error-free WLAN deployment and adaptation
- Supports MXview Wireless for dynamic monitoring and roaming playback



Reliability

- 500 V power input insulation
- Level 4 ESD protection on antenna ports
- Anti-vibration design
- -40 to 75°C operating temperature (-T models)



Security

- Robust device-level access control based on the IEC 62443 standard
- Supports the latest iteration of WPA2
- Supports HTTPS/SSL, RADIUS, and SSH
- Supports ICMP and filtering based on MAC address, IP protocol, and port

Keep Your AGVs on Track With Automatic Wi-Fi Adaptation and Optimization

Challenges

- Wireless network deployment, link status monitoring, and link maintenance are complex
- Operators need to maintain reliable wireless connectivity while dealing with changes in the Wi-Fi environment
- Maintaining seamless wireless communication is critical to keep operations running
- Wireless devices on the factory floor are subject to high EMI/RF noise, which can affect performance reliability

Moxa Solutions

AWK-1137C Series Compact Industrial 802.11n Wireless Clients

- Compact form factor to fit into AGV machines
- AeroMag for easy wireless device configuration and optimization
- Turbo Roaming for handovers under 150 ms
- Integrated antenna and power isolation providing 500 V insulation protection against electrical noise
- Anti-vibration compliant with the IEC 60068-2-6 standard
- One-to-many NAT to simplify device integration for machine builders
- -40 to 75°C operating temperature range

AWK-3131A Series Robust Industrial 802.11n Wireless Access Points

- Supports 802.11n 2 x 2 MIMO dual antennas for larger signal coverage
- AeroMag for easy wireless device configuration and optimization
- Integrated antenna and power isolation providing 500 V insulation protection against electrical noise
- -40 to 75°C operating temperature range

AeroMag Easy Deployment Automatic WLAN Setup and Optimization

- One-step setup for bulk AWK Wi-Fi device configuration
- One-click refresh for automatic AP-Client links and channel updates
- Zero-configuration when adding new devices into existing WLAN networks
- Zero-access lockdown to block unauthorized devices
- Error-free Wi-Fi network life cycle

MXview Wireless Visualized Wi-Fi Links Dynamic Monitoring and Efficient Troubleshooting

- Dynamic topology views showing the status of wireless links and changes at a glance
- Visualized roaming playback function to review the roaming history of clients
- Device dashboards for Wi-Fi APs and clients with detailed device information and performance charts
- Real-time event notifications



	AWK-4131A	AWK-3131A	AWK-1131A	AWK-1137C
Operation Mode	AP/Client/Client-router/Master/Slave	AP/Client/Client-router/Master/Slave	AP/Client	Client/Client-router/Slave
Wi-Fi Interface	802.11a/b/g/n (up to 300 Mbps data rate), Client-based Turbo Roaming with < 150 ms handover times			
Link Interfaces	1 GbE (PoE-powered)		1 GbE	2 FE, 1 RS-232/422/485
No. of Clients	Up to 60 clients per AP	Up to 60 clients per AP	Up to 30 clients per AP	-
AeroMag	AeroMag AP/Client		-	AeroMag Client
Operating Temperature	-40 to 75°C	-25 to 60°C, -40 to 75°C (-T models)	0 to 60°C, -40 to 75°C (-T models)	
Radio Certifications	FCC, CE, MIC, ANATEL, WPC, SRRC, KC, RCM			
Industrial Certifications	-	C1D2, ATEX Zone 2, IECEx	-	E mark E1

Enable Smart Railways With Ethernet

Railway systems are designed to operate for decades. Using divergent networks to support multiple services in railway systems can be costly and hard to deploy, maintain, and scale. As an IRIS-certified company, Moxa provides Ethernet-compliant railway solutions for onboard, train-to-ground, and wayside communication and control systems that enhance operational capacity, efficiency, and passenger services.

- Moxa Offers**
- EN 50155 proven reliability from trains to tracks
 - Ethernet compatibility with equipment from different train builders
 - Complete wired and wireless product portfolio
 - Quality based on IRIS Rev. 0.3

Ethernet-connected Onboard Networks

Moxa's EN 50155 Ethernet solutions enable high-bandwidth communications for CCTV, passenger information systems (PIS), passenger Wi-Fi, and other train-wide communication services in space-constrained onboard environments.

Performance

- » GbE and 10GbE for network convergence
- » 802.11n data rates of up to 300 Mbps

Security

- » Device-level cybersecurity
- » Built-in firewall protection (TN-4900 Series only)

Reliability

- » Complies with all EN 50155 mandatory test items
- » Seamless failover with network redundancy and bypass

TN-G4516 Series 10GbE Full Gigabit PoE Switches

- Up to 4 10GbE and 12 GbE ports
- Push-pull Ethernet connectors
- 8 GbE PoE ports with a 120 W total power budget

AWK-3131A-RCC Series Onboard 802.11n AP/Client

- IEEE 802.11n compliant
- Up to 300 Mbps data rate
- Auto Carriage Connection (ACC) technology for inter-carriage wireless connections

VPort 06EC-2V Series 1080P Exterior IP Cameras

- -40 to 70°C operating temperature
- Built-in front glass heater for defogging
- IP67-rated housing

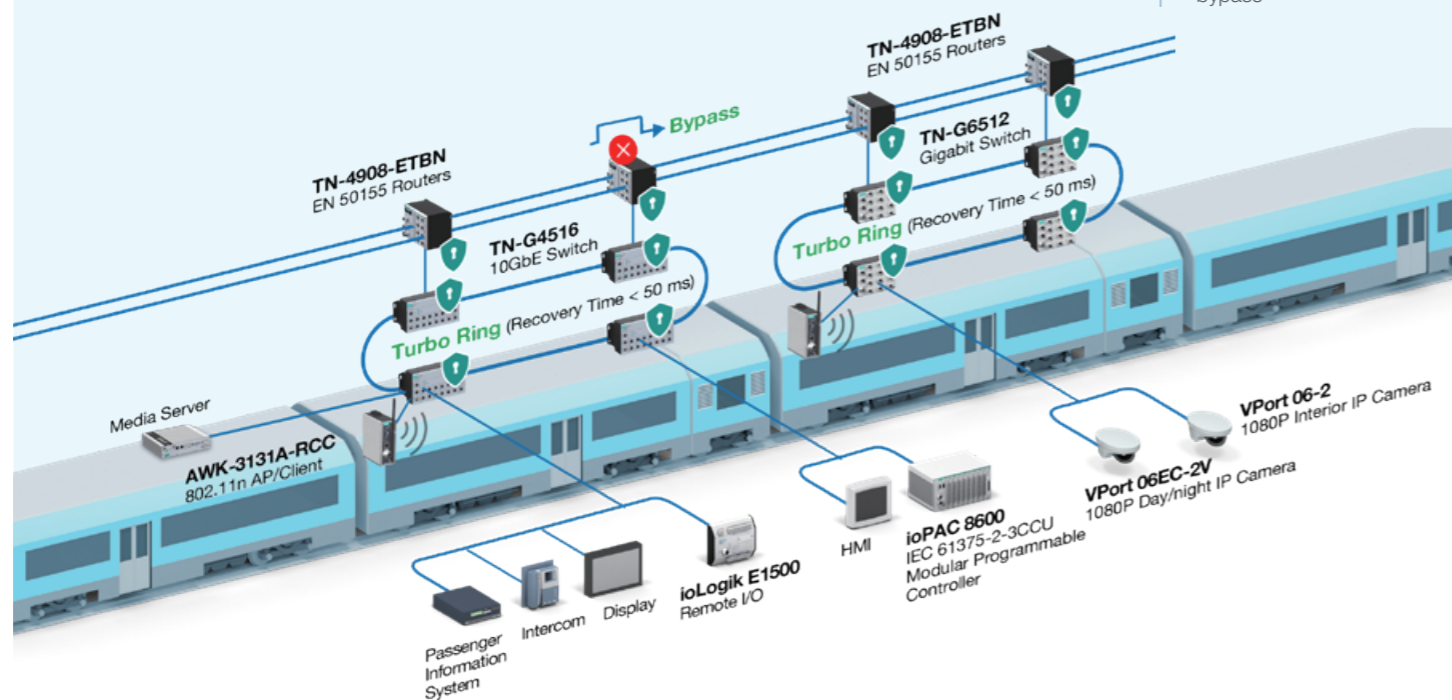

Train-to-ground Wireless Solutions

From vital train-to-ground communications (such as CBTC) to onboard infotainment systems, high bandwidth and rapid handoffs for wireless transmissions on fast-moving trains are more crucial than ever. Moxa provides robust 802.11n-based train-to-ground connectivity solutions to ensure real-time train status updates and control for smoother rides and improved passenger safety.

Performance

- » Up to 300 Mbps data rate
- » Turbo Roaming under 50 ms*

Security

- » Device-level security
- » WPA/WPA2 and 802.1x security

Reliability

- » Complies with all EN 50155 mandatory test items
- » Complies with EN 50121-4
- » IP68-rated APs and clients
- » Wi-Fi link redundancy with AeroLink Protection

AWK-3131A-RTG Series TAP-213 Series Onboard 802.11n AP/Client

- PoE-powered or dual DC inputs
- Wi-Fi redundancy with AeroLink Protection

TAP-323 Series Trackside 802.11n Dual Radio AP

- IP68-rated
- Dual-band AP and switch combo device
- Gigabit Ethernet/fiber redundancy with Turbo Chain

WAC-2004A Series Industrial Wireless Access Controller

- IEEE 802.11i/802.1x compliant security
- Up to 450 Mbps throughput for tunneling
- Supports device failover check

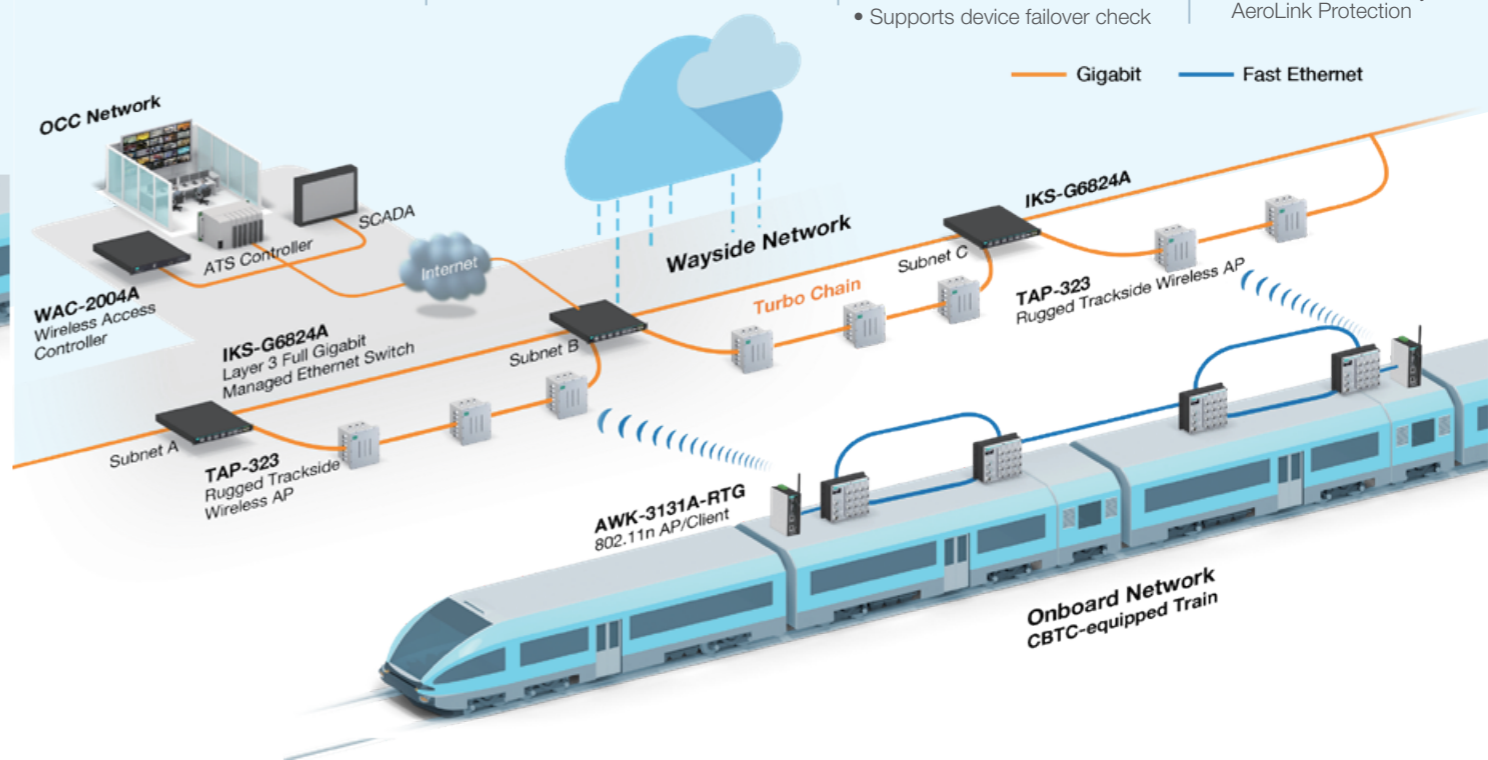

- ▶ EN 50155 Switches: TN-4908/4916-ETBN, TN-G6512, TN-G4516, TN-4500A Series, TN-5500A Series
- ▶ EN 50155 IP Cameras: VPort 06 Series, VPort 06EC Series
- ▶ EN 50155 Wireless LAN and Controllers: AWK-3131A-RCC, AWK-3131A-RTG, TAP-213, TAP-323, WAC-2004A

	TN-4908/4916-ETBN	TN-G6512	TN-G4516	TN-4500A Series	TN-5500A Series
10GbE Ports	-	-	4	-	-
GbE Ports	8	12	12	Up to 4	Up to 2
1G Fiber	-	-	-	Up to 2 ports	Up to 2 ports*
FE Ports	Up to 8	-	-	12/24	8/16
PoE Ports	Up to 12 PoE+	8 PoE+	Up to 12 PoE+	Up to 20 PoE+	Up to 8 PoE+

	VPort 06 Series	VPort 06EC Series
Day/Night	Day	Day/Night
Resolution	HD or 1080P	1080P
Power Input	PoE or 24 VDC	PoE (24 VDC for heater)
Operating Temperature	-25 to 55°C -40 to 70°C (-T models)	
Protection	IP66, IK10	IP67, IK7

	AWK-3131A-RCC	AWK-3131A-RTG	TAP-213	TAP-323	WAC-2004A
Best Scenarios	Inter-carriage, passenger Wi-Fi	Train-to-ground	Train-to-ground	Train-to-ground	Wi-Fi Controller
Wi-Fi Capability	802.11a/b/g/n	802.11a/b/g/n	802.11a/b/g/n	802.11a/b/g/n	-
Network Interfaces	1 GbE	1 FE	1 GbE + 1 GSFP	2 GSFP + 4 FE	1 GbE
Wi-Fi Roaming	Client-based Turbo Roaming* < 150 ms handover time	Controller-based Turbo Roaming* < 50 ms handover time (with WAC Series)			-
Reliability	-40 to 75°C operating temperature		IP68-rated, -40 to 75°C operating temperature		-

*Available for the TN-5510A Series only.

*Turbo Roaming performance may vary based on infrastructure and parameter configurations. Refer to the product manuals for more information.

IEC 61850 Visibility and Reliability for Substation Digitalization

The IEC 61850 standard defines communication protocols for intelligent electronic devices (IEDs) and enables interoperability between devices from different vendors. However, interoperability alone is not enough to ensure reliability and security for modern substations.

Moxa introduces MXview Power that provides deep visibility into substation communication and monitoring. Dedicated to IEC 61850 power network monitoring, MXview Power provides visibility not only of industrial Ethernet networks but also of IED statuses, GOOSE messages, and redundant connections in PRP/HSR networks.

Working with MXview Power, the PT-G7828/G7728 Series switches are ideal for transforming traditional substation communications for a digitalized substation automation system (SAS). The PT-G7828/G7728 switches are compliant with the latest IEC 61850-3 Edition 2 Class 2 and IEEE 1613 Class 2 standards to achieve error-free delivery in harsh conditions.

Embedded with the innovative GOOSE Check function, MMS server capability, and nanosecond-level time synchronization, the PT-G7828/G7728 switches ensure reliable data transmission in power substations.

Built for Maximum System Availability

PT-G7828/G7728 Series

Layer 3 and Layer 2 28-port Gigabit Rackmount Switches

- ▶ Minimize Errors
- ▶ Detect Errors
- ▶ Fix Errors



MMS for Power SCADA Supervision

With a built-in MMS server, the PT-G7828/G7728 switches can be controlled, monitored, and managed via a centralized Power SCADA system for enhanced efficiency and availability.

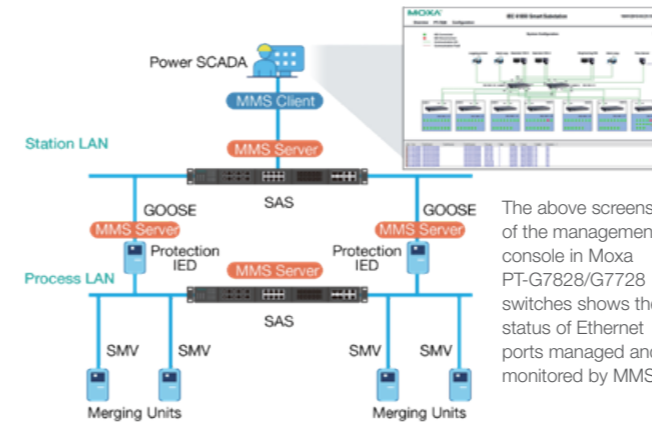

GOOSE Check

The PT-G7828/G7728 switches feature the GOOSE Check function that monitors GOOSE packets and sends instantaneous alerts to the Power SCADA and MXview Power when timeouts or tampered GOOSE packets are detected.

Together with GOOSE Lock, which creates an allowlist of legitimate GOOSE packets, the PT-G7728/G7828 can block malicious traffic to defend the network.

Advanced Function
 GOOSE Lock Tamper Response N/A Apply

Update Interval: every five seconds

Index	APP ID	GOOSE Address	IED Name	VID	Ingress Port	Rx Counter	Status	Type
1	1	01:0c0d:01:00:00	BC_CONTCTRL	1	1-2	85	Health	Static
2	1	01:0c0d:01:00:01	BC_CONTCTRL	1	1-2	85	Health	Dynamic
3	1	01:0c0d:01:00:02	BC_CONTCTRL	1	1-2	85	Timeout	Dynamic
4	1	01:0c0d:01:00:03	BC_CONTCTRL	1	1-2	85	Health	Dynamic
5	1	01:0c0d:01:00:04	BC_CONTCTRL	1	1-2	85	Health	Static
6	1	01:0c0d:01:00:05	BC_CONTCTRL	1	1-2	85	Health	Dynamic
7	1	01:0c0d:01:00:06	BC_CONTCTRL	1	1-2	85	Tampered	Static
8	1	01:0c0d:01:00:07	BC_21CTRL	1	1-2	85	Health	Dynamic

Reset Delete Set Static

Use Case

PRP/HSR Networks and IEC 61850 System Visibility for Substation Digitalization

A traditional substation wanted to transform into a digital IEC 61850 substation to implement accurate time synchronization between its feeder protection bays. They used Moxa PT-G7728 switches to scale up existing networks for seamless PRP/HSR data transmissions and used MXview Power for deep device visibility and management.

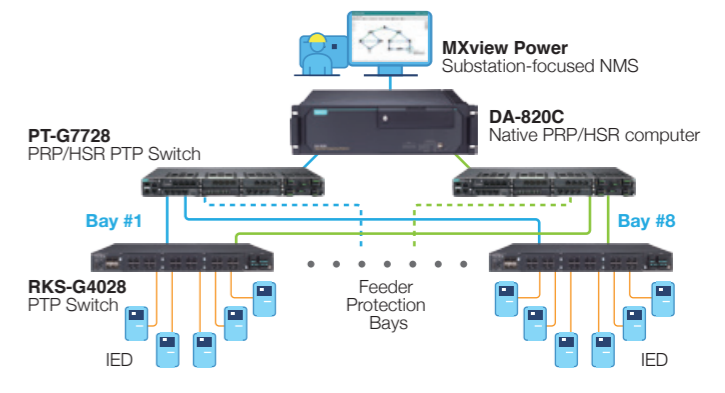

Extended Performance

- Up to 28 GbE ports with RJ45/SFP/PoE+ modules
- Up to 24 GbE PoE+ connections
- Quad-GbE port PRP/HSR module for zero-time failover
- All ports support IEEE 1588 v2 PTP
- IEC 61850 QoS to prioritize critical GOOSE/SMV transmissions

Purpose-built Management

- Real-time visibility of network and device status
- Built-in MMS to support centralized monitoring by Power SCADA
- Embedded GOOSE packet monitoring for quick troubleshooting
- 3-second dying gasp to trigger alarms and error logging during a power failure for quick troubleshooting
- PTP-sync LED that shows the time-sync status

All-round Reliability

- Security features based on the IEC 62443 standard
- IEC 61850-3 and IEEE 1613 compliance
- Supports Turbo Ring, Turbo Chain, and PRP/HSR for failover redundancy
- Dual redundant isolated power modules
- Hot-swap design for continuous availability and easy maintenance

Network Requirements

- Ensure zero-time redundancy and precise time synchronization
- Ensure always-on zero-packet-loss communication
- Easy management of IEC 61850 data and networks

Why Moxa

- Complete product portfolio that supports IEEE 1588 PTP solutions
- Supports zero-packet-loss transmissions in harsh environments with EMI
- Hot-swappable modules that can be inserted or replaced for expansion and scalability without system downtime
- Supports real-time viewing of the PRP/HSR topology and GOOSE flow details of nodes

MXview Power

Substation-focused Network Management Software

- Visualize the substation network topology in real time
- Automatically scan and detect unauthorized IED devices for preemptive protection
- Automatic and concise visibility of PRP/HSR dual LAN topology for simplified management
- Instant visibility of critical packets such as GOOSE messages to speed up troubleshooting
- Instant visibility of key components such as fiber interfaces to speed up troubleshooting

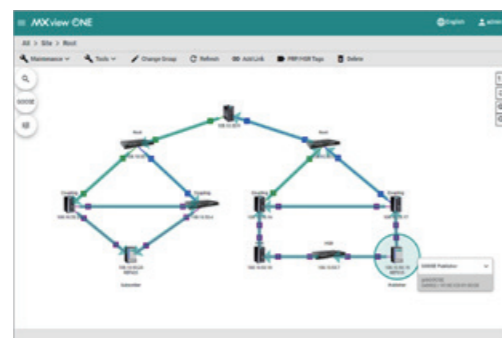

▶ IEC 61850-3 Switches

	PT-G7828	PT-G7728	PT-7828/7728	PT-7528	PT-7728-PTP	PT-G503	RKS-G4000	MDS-G4000
Device Design	Modular	Modular	Modular	Fixed ports with single-slot module	Modular	Compact fixed ports	Modular	Modular
Max. No. of Ports	28 GbE	28 GbE	4 GbE + 24 FE	4 GbE + 24 FE	4 GbE + 24 FE	3 GbE	28 GbE	4 10GbE + 24 GbE
Max. No. of PTP Ports	28	28	-	-	14	3	28	28
Zero-time Redundancy	-	PRP/HSR	-	-	PRP/HSR	PRP/HSR	-	-
Proprietary Redundancy	Turbo Ring, Turbo Chain (Ethernet recovery time < 20 ms, Gigabit recovery time < 50 ms)							
RSTP Grouping	-	✓	-	-	✓	✓	-	-
MMS Server	✓	✓	✓	✓	✓	✓	-	-
GOOSE Check	✓	✓	-	-	-	-	-	-
IEC 61850 QoS	✓	✓	✓	✓	✓	-	-	-
Industrial Certifications	IEC 61850-3, IEEE 1613 Class 2							
Operating Temperature	-40 to 85°C						-40 to 75°C	